



# MITSUBISHI TRITON (LHD) 2020 +



## General Notes

- Read through the fitting instructions before installation of accessory.
- Ensure all recyclable components and packaging are discarded and recycled following local recycling regulations.
- Safely store and protect any removed vehicle components.

## Harnesses Supplied

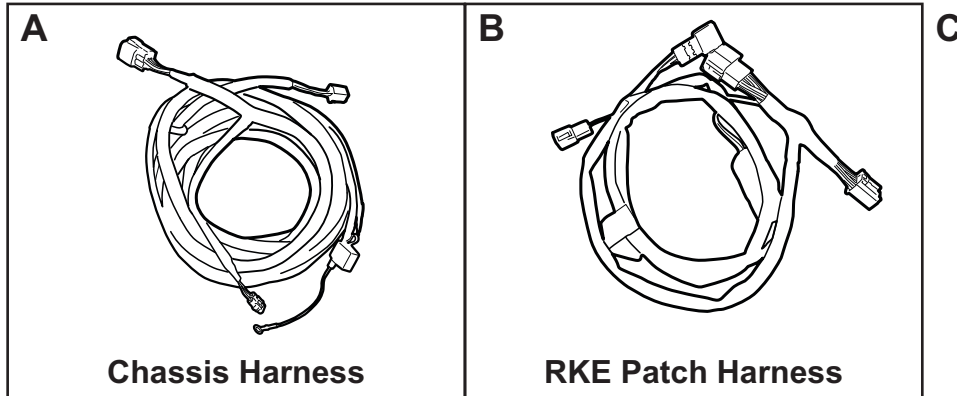

## Tools Used

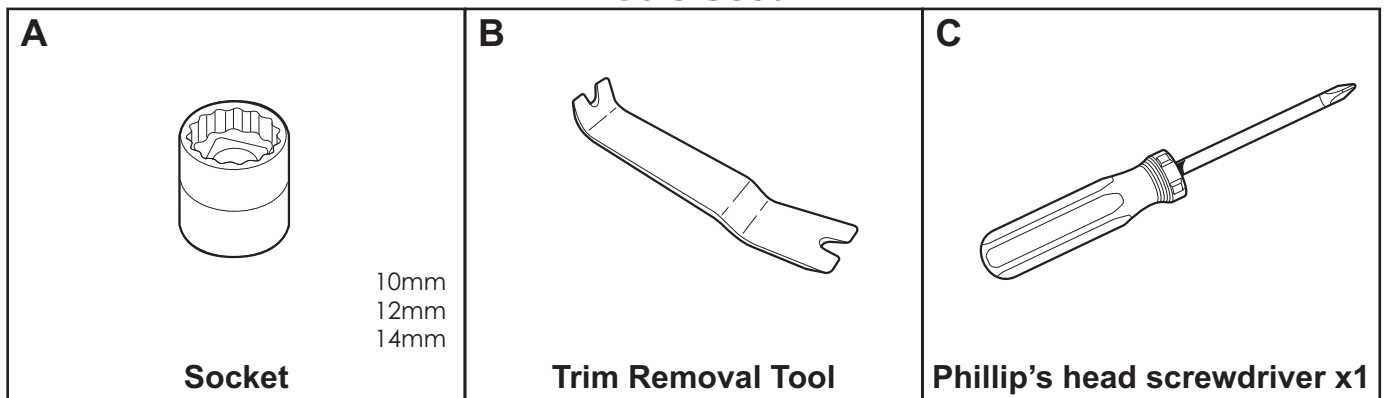

Harness Layout

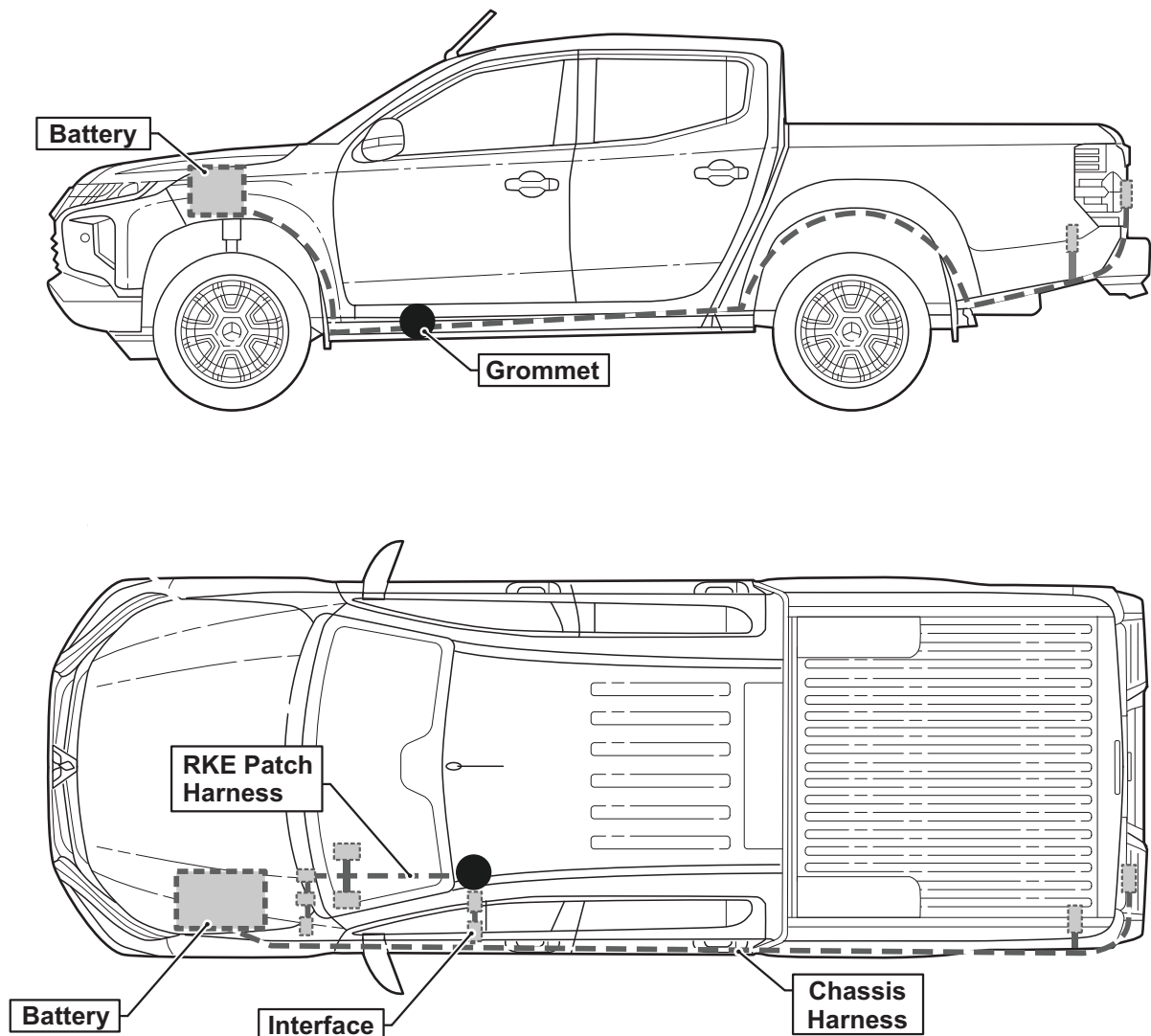

# MITSUBISHI TRITON (LHD) 2020+

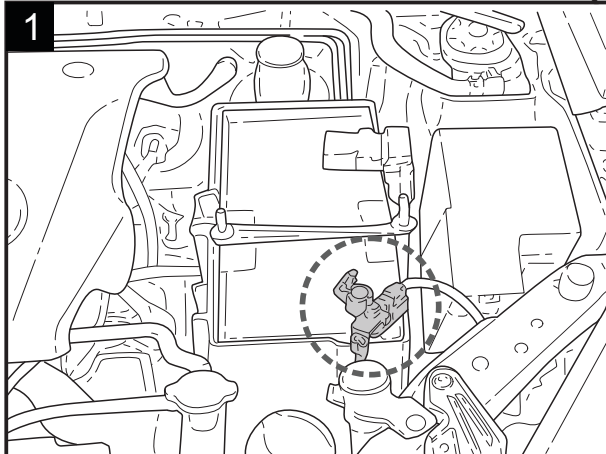

- Note down all clock and radio settings.
- In the Engine Bay disconnect the negative battery terminal.

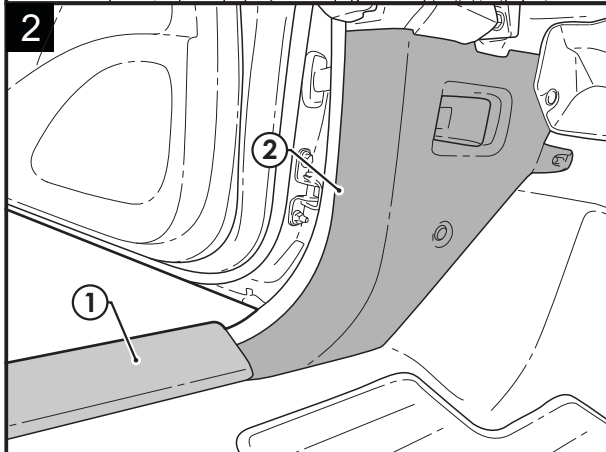

- Inside the car, remove LHS scuff plate (1) and kick panel (2).

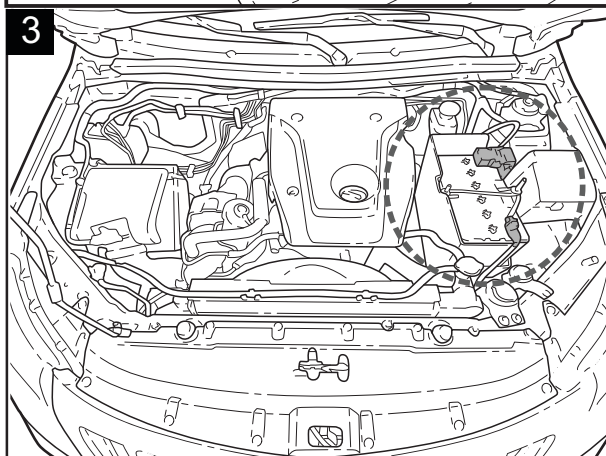

- Connect the chassis harness positive to the positive and negative to the negative terminals of the battery.

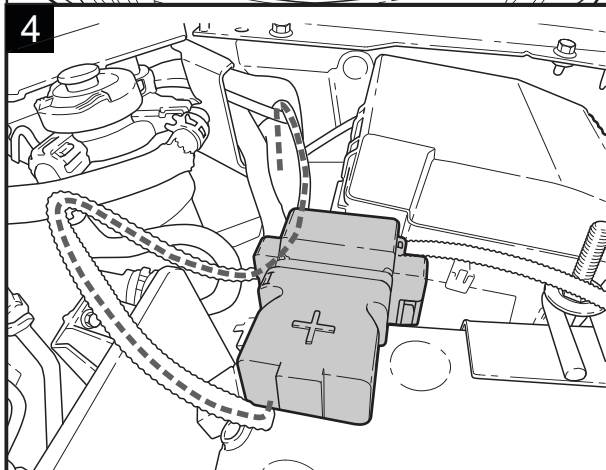

- Route harness down the engine bay following existing vehicle harness to LHS rear of the car.

# MITSUBISHI TRITON (LHD) 2020+

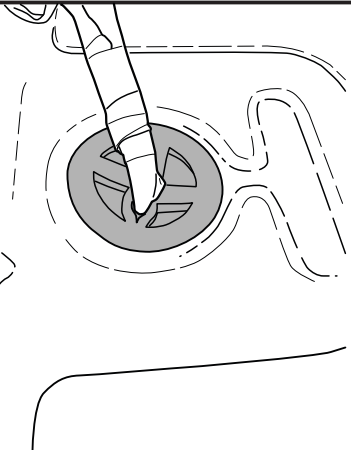
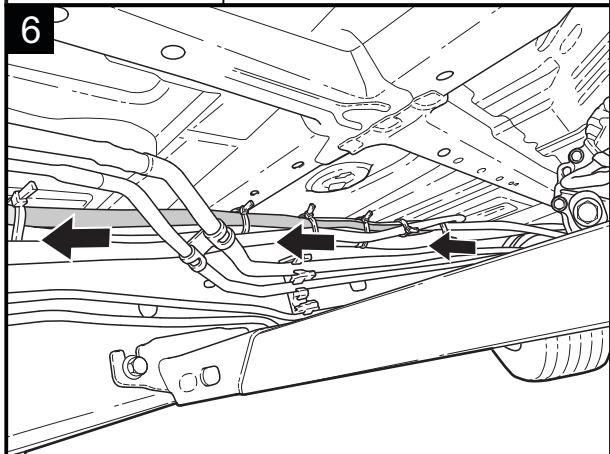
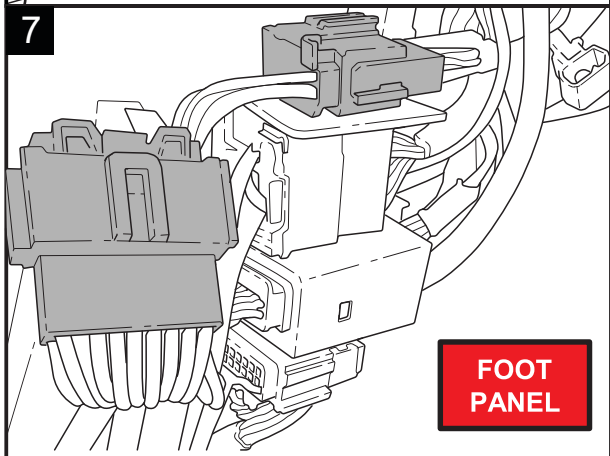
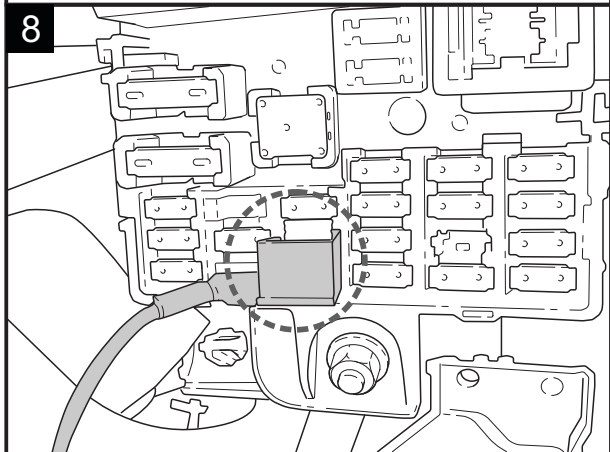
<p>5</p> 	<ul style="list-style-type: none"><li>• Under the LHS driver seat, remove the blanking grommet located under the carpet and feed in the grommet branch of chassis harness while making a watertight seal.</li></ul>
<p>6</p> 	<ul style="list-style-type: none"><li>• Continue routing the power harness to the LHS rear following the chassis rail securing it to the existing vehicle harness at every 300mm using supplied cable ties.</li></ul>
<p>7</p> 	<ul style="list-style-type: none"><li>• Inside LHS kick panel area find 18-way connector and patch in RKE Patch Harness.</li></ul>
<p>8</p> 	<ul style="list-style-type: none"><li>• Get access to LHS fuse box under the steering column and patch in the demister connector using the fuse patch provided.</li></ul>

# MITSUBISHI TRITON (LHD) 2020+

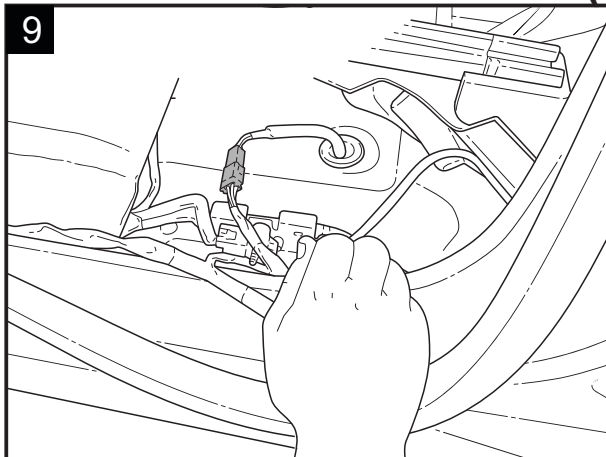

9

- Route the 6-way male interface connector under the LHS driver seat and connect it with already routed 6-way female connector on the chassis harness.

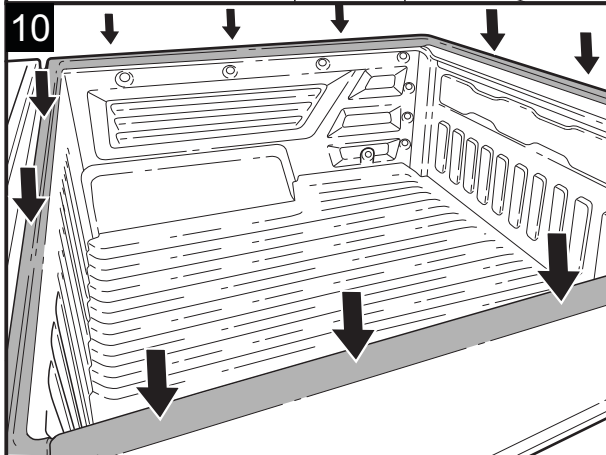

10

- Degrease the bed rail.

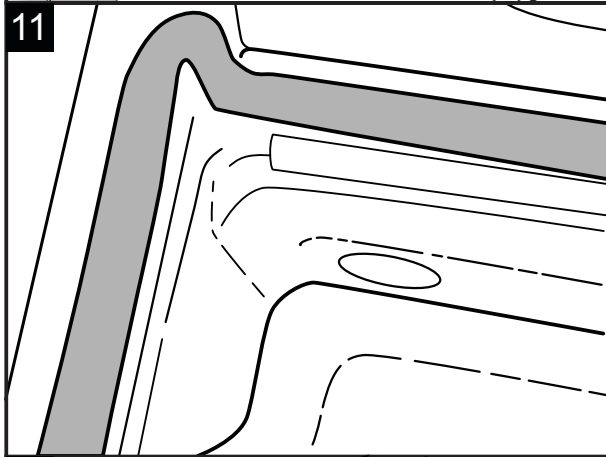

11

- Apply mounting tape in one piece on the upper side of the bed rail.

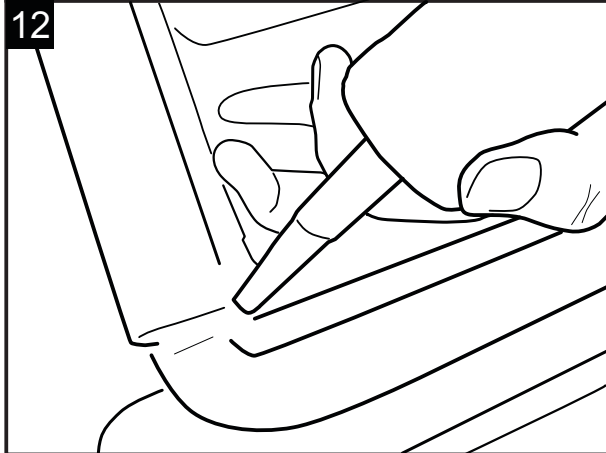

12

- Apply silicone in the connections of the front bed area.

# MITSUBISHI TRITON (LHD) 2020+

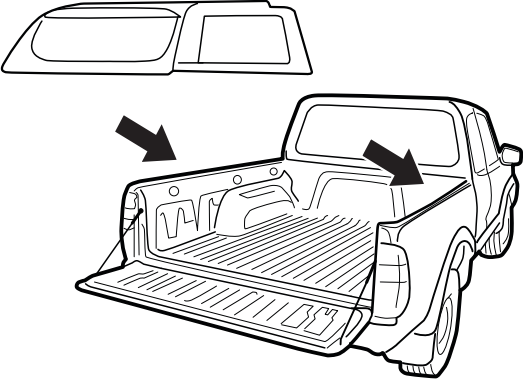
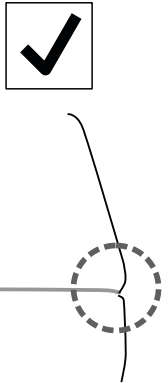
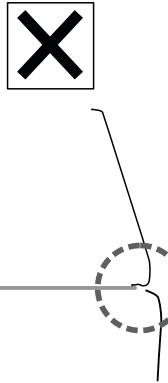
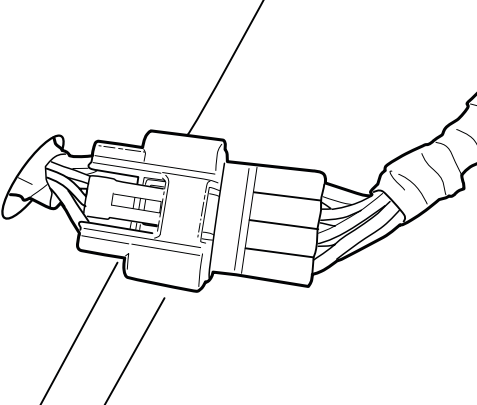
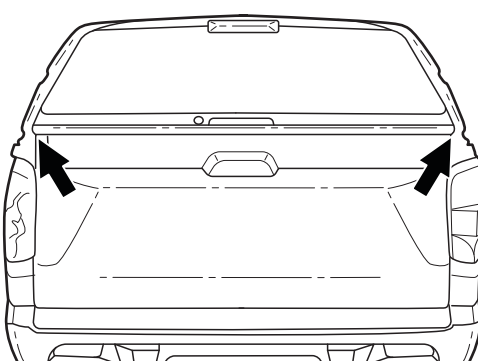
<p><b>13</b></p> 	<ul style="list-style-type: none"><li>• Position with 4 people the hardtop with closed tailgate on the vehicle.</li></ul>	
<p><b>14</b></p> 		<ul style="list-style-type: none"><li>• The rubber of the hardtop tailgate has to slightly touch the car tailgate.</li></ul>
<p><b>15</b></p> 	<ul style="list-style-type: none"><li>• Connect the 8-way female canopy interfacing connector of chassis harness with 8-way male connector on the canopy harness.</li></ul>	
<p><b>16</b></p> 	<ul style="list-style-type: none"><li>• Close the tailgate of the hardtop and ensure that it fits nicely with the tailgate of the car.</li></ul>	

# MITSUBISHI TRITON (LHD) 2020+

17

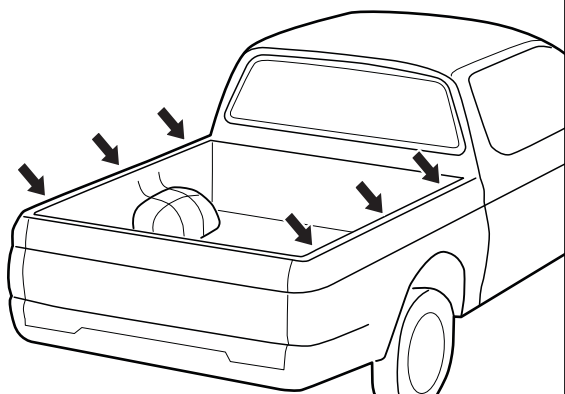

- Secure the hardtop at the indicated places with the supplied clamps.

18

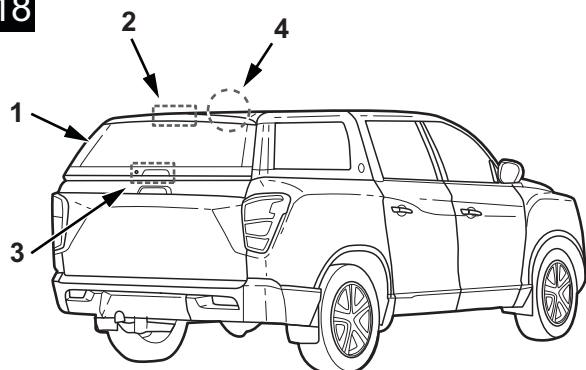

- Test the following points:
  1. Rear window defroster
  2. Third brake light.
  3. Central locking system
  4. Interior light